

# PRODUCT DATA

COMFORT CT500/POLAR BY NILAN



## Ventilation & passive heat recovery



Domestic



Passive  
heat recovery



Ventilation  
< 500 m<sup>3</sup>/h

# COMFORT CT500/POLAR

## Product description

Based on the many years' experience from the Comfort series, Nilan has developed a future-proof system, Comfort CT500, that meets the requirements of ventilation systems.

The unit is constructed to ensure low energy consumption by optimising the air flows in the system and thereby reducing the internal pressure loss, as well as using quality components with low energy consumption.

We have thereby developed an energy-efficient ventilation system with heat recovery for homes and smaller commercial buildings with a ventilation requirement of up to 500 m<sup>3</sup>/h.

Comfort CT500 is factory tested and ready for use. Installation and commissioning must be performed by an authorised electrician.



*Comfort CT500 is also available in a Polar version with built-in pre-heating element, to protect the heat exchanger from ice.*

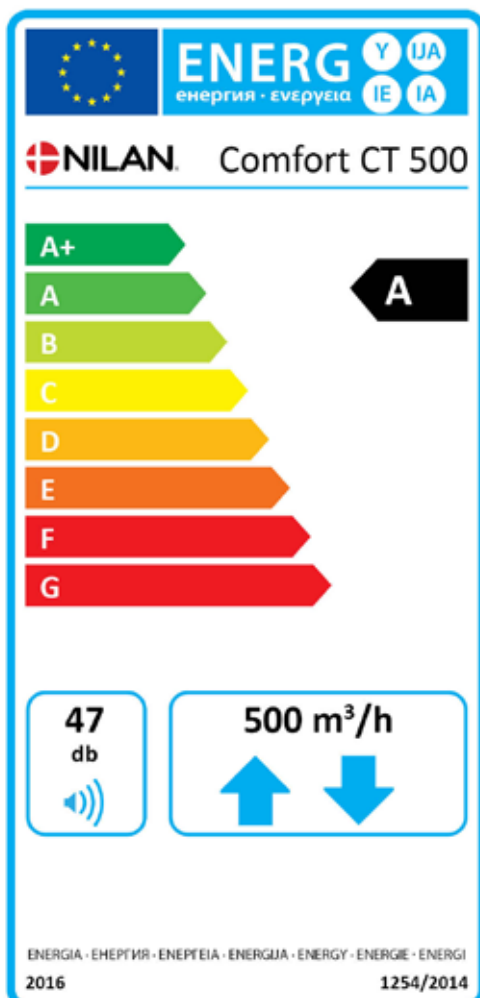

Time controlled alarm for filter change.  
Easy filter access - the top front panel manually unscrews easily.

There is plenty of space to replace filters and vacuum the filter space.

Visual alarm for filter change.

100 % automatic bypass function that carries the air past the counterflow heat exchanger when heat recovery is not required.

Efficient counterflow heat exchanger providing high temperature efficiency and low pressure loss, resulting in good heat recovery and low energy consumption.

With built-in humidity control system for ventilation on demand.

Low speed ventilation at low humidity levels and high speed ventilation at high humidity levels (e.g. a bath).

Flexible condensate drain design means that the system can be fitted horizontally, vertically or at an angle.

Can be connected to an external water or electrical pre-heating element

Aluzinc steel plate, white powder coating (RAL9016)

The unit comes with a clear and user-friendly HMI touch panel. The modern CTS602 control panel runs Modbus communication.

Chamber fan with B-wheel runs on energy-saving EC motors.

Stepless regulation at four different levels.



User App solution via gateway  
LAN/WiFi is available as an accessory

# TECHNICAL DATA

## Technical specifications

Dimensions (W x D x H)	715 x 573 x 1000 mm
Weight	59 kg
Plate type casing	Aluzinc steel plate, white powder coating RAL9016
Heat exchanger type	Polyethylenerephthalat counterflow heat exchanger
Fan type	EC, constant rotation
Filter class	ISO Coarse >90% (G4)
Duct connections	Ø 160 mm
Condensate drain	PVC, Ø20x1.5 mm
Leakage classification	A1

Supply voltage	230 V (±10 %), 50/60 HZ
Max. input/power	338 W/1.5 A
Max. input/power (Polar)	1538 W/6.7 A
Tightness class	IP31
Standby power	3.4 W
Ambient temperature	-20/+40 °C
Heat loss	0,82 W/m²K
Heat loss classification	T2

\*1 Testet according to EN13141-7  
\*1 Testet according to EN1886

SEC* average climate	-39.6 kWh/(m².a)
SEC* cold climate	-77.2 kWh/(m².a)
SEC* warm climate	-16.4 kWh/(m².a)
SEC-Class	A
Type	Two-way ventilation unit for residential
Type of drive	Variable speed drive
Type of heat recovery system	Recuperative (counterflow heat exchanger)
Thermal efficiency of heat recovery	85 %
Maximum flow rate	500 m³/h (100 Pa)
Electric power input of fan drive, including any motor control equipment, at maximum flow rate	338 W
Sound power level L <sub>WA</sub>	47 dB(A)
Reference flow rate	0,097 m³/s (350 m³/h)
Reference pressure difference	50 Pa
SPI	0,22 W/(m³/h)
Central demand control	0.85
Maximum internal leakage	1.1 %
Maximum external leakage	1.4 %
Visual filter warning	An alarm on the user panel appears when filters need changing.  To maintain the performance and energy efficiency of the unit it is very important to change filters regularly.
Disassembly instructions	www.nilan.dk

AEC - annual electricity consumption	240 kWh/year (100 m²)
AHS** average climate	4494 kWh (100 m²)
AHS** cold climate	8792 kWh (100 m²)
AHS** warm climate	2109 kWh (100 m²)

\*\* Annual heating saved

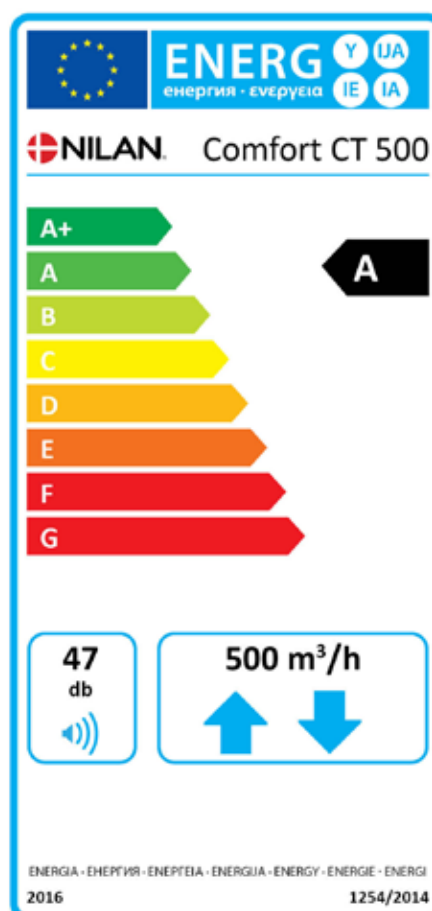

\* Specific energy consumption

## Dimensional drawing

All dimensions are in mm.

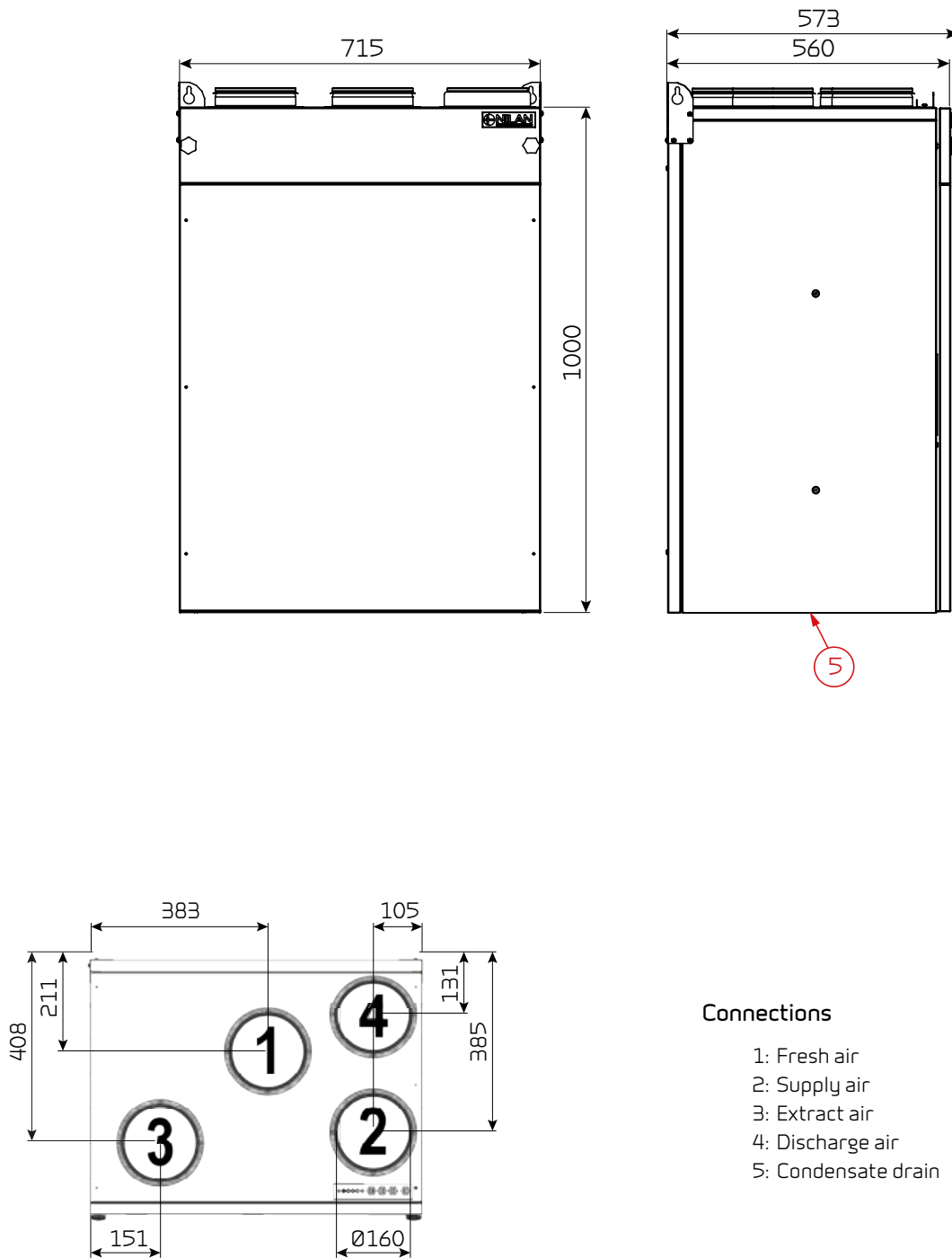

### Connections

- 1: Fresh air
- 2: Supply air
- 3: Extract air
- 4: Discharge air
- 5: Condensate drain

# PLANNING DATA

Nilan units are tested in accordance with the valid standards of accredited independent test institutes.

## Capacity

Capacity of standard unit as a function of  $q_v$  and  $P_{t,ext}$ .

SEL values according to EN 13141-7 are for standard units with ISO Coarse >90% (G4) filters and without heating element.

SEL values comprise the unit's total power consumption incl. control.

**Attention! The SEL values are measured and stated as a total value for both fans.**

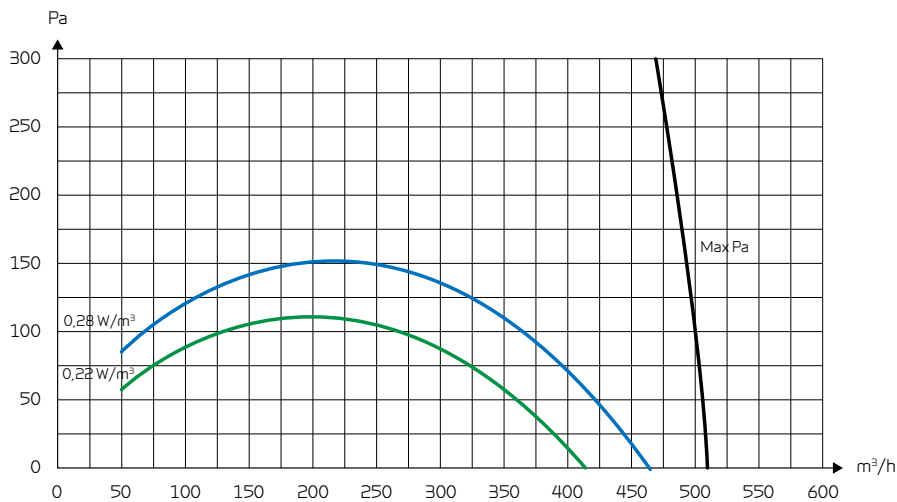

## Temperature efficiency

Temperature efficiency for units with counterflow heat exchanger according to EN308 (dry).

Temperature efficiency EN308:  $\eta_t = (t_{\text{supply air}} - t_{\text{fresh air}}) / (t_{\text{extract air}} - t_{\text{fresh air}})$

Temperature efficiency PH  $\eta_{WRG} = ((t_{\text{extract air}} - t_{\text{discharge air}}) + P_{el} / (m * c_p)) / (t_{\text{extract air}} - t_{\text{fresh air}})$

- $P_{el}$  is output for the system
- $m$  is the mass flow of air
- $c_p$  is the specific heat capacity

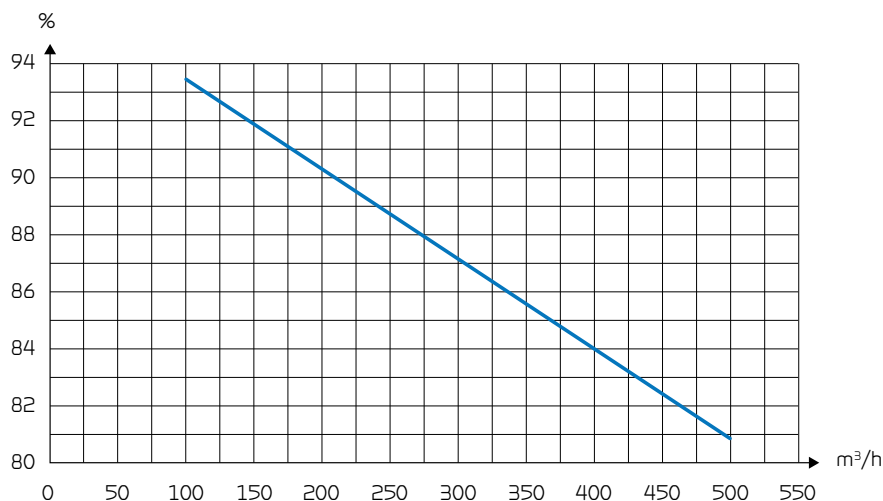

## Sound data

Sound data for  $q_v = 400 \text{ m}^3/\text{h}$  and  $P_{t, \text{ext}} = 100 \text{ Pa}$  according to EN 9614-2 for surfaces and EN 5136 for ducts.

Sound output level  $L_{WA}$  drops with falling air volume and falling back pressure.

Sound output level  $L_{pA}$  at a given distance will depend on acoustic conditions in the place of installation.

### Sound output level ( $L_{WA}$ )

Octave band Hz	Surface dB(A)	Supply air dB(A)	Extract air dB(A)
63			
125		59	48
250		62	51
500		64	50
1000		65	48
2000		64	39
4000		60	27
<b>Total ±2 dB(A)</b>	48	70	52

# OPERATION

## Intelligent humidity control

Nilan's humidity control automatically adapts to the needs of inhabitants or the building itself.

The intelligent CTS602 control unit does not require a set air humidity level (RH) to manage the air exchange. Using the integrated humidity sensor, the control unit calculates the average humidity over the past 24 hours and regulates the air flow accordingly.

Consequently the unit's efficiency is based on actual instead of theoretical air humidity levels.

Automatically adapting to air volume requirements saves energy as the number of persons in a home is relevant as to how much humidity is produced.

The unit also adjusts automatically to summer and winter levels.

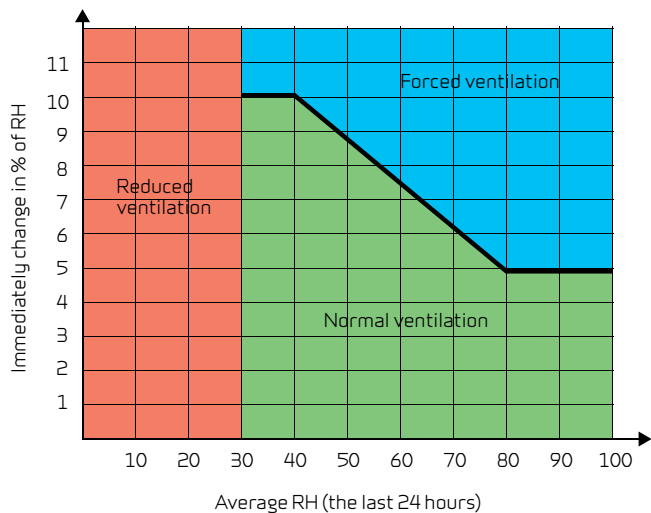

*If the air humidity changes by more than 5-10% in relation to the average level, the unit responds with a higher rate of air exchange accordingly.*

*When air humidity falls below 30%, ventilation scales back automatically. The percentage is adjustable from 15 - 45%.*

## Functional diagrams

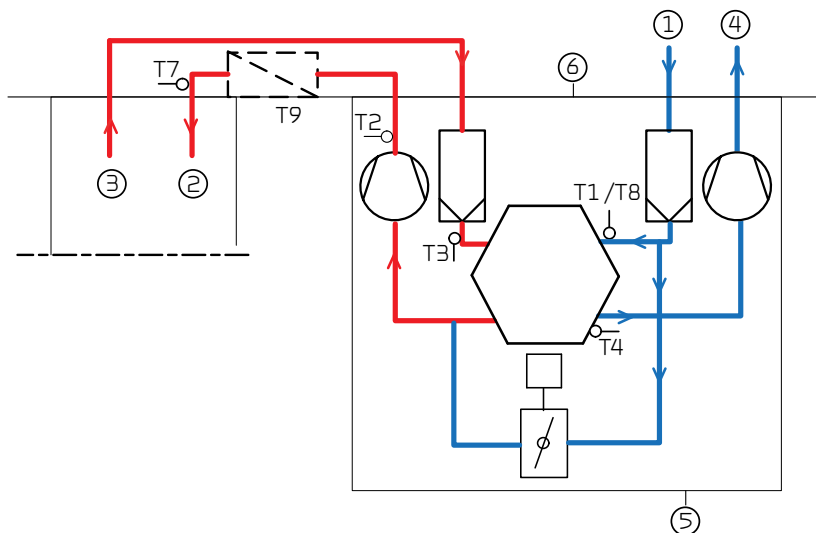

### Automation

- T2/T7: Supply air sensor
- T3: Extract air sensor
- T4: Discharge air and defrost sensor
- T8: Fresh air sensor
- T9: Heating element

### Connections

- 1: Fresh air
- 2: Supply air
- 3: Extract air
- 4: Discharge air
- 5: Condensate drain
- 6: Electric and water heating

## Capacity - Heating element (accessory)



### Electrical heating element

The electrical heating element is fitted in the supply air duct at a distance of min. 2 x duct diameter from the system's fresh air connection pipe (normally min 320 mm.) and connected to the CTS602 control panel and 230 V supply.

The electrical heating element can supply up to 1,2 kW of heat.



### Water heating element for duct fitting

The water heating element is designed to be built into the duct and must be connected to the primary heating supply and the CTS602 control. The water heating element includes copper pipes and aluminium fins.

Capacities can be seen in the table below.

### Capacity water heating element

Temperature input/output [°C]	Water side			Air side			
	Flow [m³/h]	Pressure drop [kPa]	Output [kW]	Flow [m³/h]	Temperature before WHE* [°C]	Temperature after WHE* [°C]	Pressure drop over WHE* [Pa]
40/30	0.04	0.85	0.52	100	16	31.1	2
	0.06	1.25	0.64	135	16	29.8	3
	0.08	2.18	0.87	210	16	28.1	6
	0.10	3.38	1.13	310	16	26.7	11
60/40	0.04	0.69	0.94	100	16	43.5	2
	0.05	1.00	1.16	135	16	41.1	3
	0.07	1.58	1.58	210	16	38.0	6
	0.09	2.78	2.04	310	16	35.3	11
70/40	0.03	0.40	1.06	100	16	47.0	2
	0.04	0.58	1.30	135	16	44.2	3
	0.05	1.00	1.76	210	16	40.5	6
	0.06	1.58	2.26	310	16	37.3	11

\* Water heating element.

# AUTOMATION CTS602

## CTS602 Control

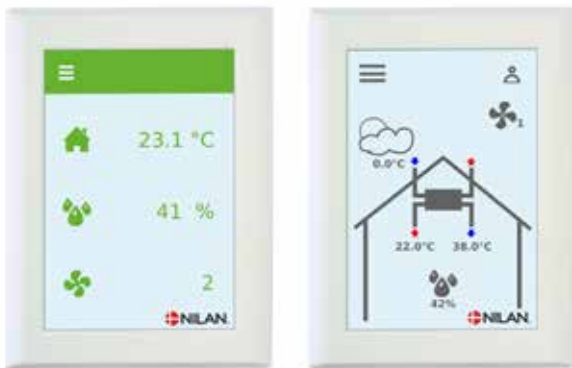

The CTS602 HMI touch panel is featuring a wide range of functions, e.g., menu-controlled operation, weekly programme settings, filter monitor with timer, fan speed adjustment, summer bypass (free cooling), supply-heating element control, error messages etc.

The CTS602 comes with factory settings, including a default setting which can be customised to operational requirements to achieve optimum operation and utilisation of the system.

There is an option for selecting between 2 front page images for the main screen.

Operating instructions for the CTS 602 can be found in a separate user manual supplied with the unit.

## Nilan User App

By purchasing a Nilan gateway, the user can gain access to the unit via a Nilan User App. The App enables the user to access and monitor the current operation, also from the outside of the property.

The App allows you to adjust the default settings of, for instance, room temperature, fan speed level and the humidity control system.

The App shows when filter change is next due. This is an important function, and you are automatically notified when filters need changing or an alarm is triggered.

It also provides you with useful trend curves so you can follow the operation of the unit for the previous week with regards to, for instance, room temperature or humidity level.

Using a LAN connector, you connect the gateway to the Modbus of the unit and then to the user's internet router via a LAN or a WiFi connection. This creates a secure cloud connection between the unit and the smartphone.



## External communication

The CTS602 control unit communicates by default with Modbus RTU RS485 communication. A CTS system using this form of communication can easily be connected to the unit.

Nilan units have an open Modbus communication, i.e. not only can the unit be monitored, but its operation can also be set in the same way as it can via the operating panel.

The protocol is by default set up for a Modbus RTU30 address; however, values can be set between 1 and 247.

A Modbus converter allows you to connect one or more units to a computer to monitor and control the unit.

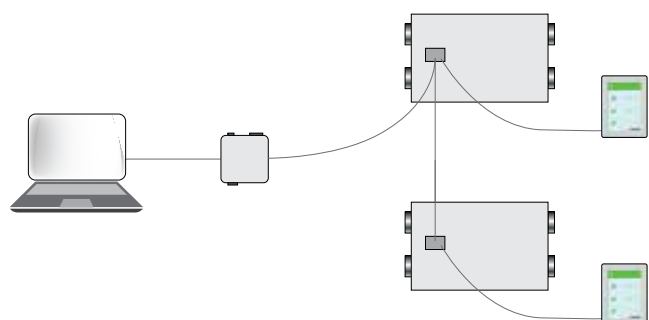

Functions overview		+ Standard - Accessories
Alarms	Description of errors indicated with alarms. Alarm log displaying the latest 16 alarms.	+
Joint alarm	The CTS602 control system has an output signal that is activated in the case of an alarm. It can be connected to, for example, external automation.	
Filter monitor	Filter alarm with timer that can be set to 30/90/180/360 days.	+
Data display	An overview of the current operation with regards to temperatures, fan speed level etc.	+
Week program	The CTS602 control system has 3 week programs that can be set individually (the default setting is "off").	+
Humidity control system	Enables a higher or lower degree of ventilation at a high/low level of humidity.	+
Air quality	Enables you to adjust the degree of ventilation depending on the CO <sub>2</sub> level in the air.	-
Winter low	You can prevent a low level of humidity in the dwelling by activating low ventilation at low outdoor temperatures.	+
Temperature regulation	Enables you to control the operation of the unit in accordance with the room temperature.	+
Summer/winter mode	You can set the unit to operate in summer or winter mode.	
Language	You can choose from more than 10 languages in the control panel.	+
User levels	The menu in the control panel is divided into 3 user levels: User/Installer/Factory.	+
User selection 1	Enables you to override the operating mode via an external potential free signal.	+
User selection 2	Enables you to override the operating mode as well as user selection 1 via an external potential free signal.	-
Electrical after-heating element	An electrical after-heating element allows you to control the supply air temperature. In this way the unit can help heat the dwelling.	-
Water after-heating element	A water after-heating element allows you to control the supply air temperature. In this way the unit can help heat the dwelling.	-
Frost protection	In order to protect a potential water after-heating element against frost damage, the unit will stop and display an alarm if the temperature in the water after-heating element becomes too low.	-
Air exchange	Stepless setting of four fan speed levels. The supply air and the extract air can be set individually.	+
De-icing	Based on temperature, this automatic function de-ices the counterflow heat exchanger if ice has formed within it.	+
Room low	Safety function that will cause the ventilation unit to stop if the heating system for the dwelling fails. This will prevent the unit from cooling the dwelling even further.	+
External heating	The ventilation unit can control an external heat supply in accordance with the current room temperature.	+
External fire automation system	You can connect the ventilation unit to an external fire automation system or to a fire thermostat. This will signal to the unit whether to stop or continue operation.	+
Integral fire automation system	The ventilation unit is available with an integral fire automation system that can control fire and smoke dampers.	-
Pressure sustaining regulator	You can install a pressure sustaining regulator on the side of both the extract air and the supply air (applies to CTS602 control - not CTS602 light).	-
Delayed start-up	You can activate a delayed start-up of the fans if you install, for instance, a shut-off damper.	+
Restore settings	You can save the current settings and subsequently restore them if, for instance, the user has altered the settings on the unit. You can also reinstall the default settings.	+
Manual operation	Different functions can be tested manually.	+
Energy saving function	You can activate a power saving function of the operation.	+
Modbus	You can set the Modbus address of the unit. The default setting is 30.	+
Data logging	It is possible to log the operational data of the unit every 1 - 120 min. Alarms are logged when they occur.	+
Control panel	You can choose from 2 different images for the main screen.	+

You can find further information about all the functions in the Software and Installation instructions for the unit.

# ACCESSORIES



## Electrical pre-heating element (Frost protection)

To prevent the highly efficient counterflow heat exchanger from freezing, we recommend that you fit an electrical pre-heating element. The element consumes very little energy but improves heat recovery. The net result is more cost-efficient operation.



## Electrical heating element incl. regulation

When fitting an electrical heating element, fresh air temperatures can be raised to desired levels at any time. The electrical heating element is supplied ready to fit into the fresh air duct and, for easy fitting, the device is pre-fitted with all the required sensors (*expansion PCB included*).



## Water heating element incl. regulation

The supply temperature can always be raised to the required level using a water heating element. The water heating element is designed to be built into the duct and must be connected to the primary heating supply. Supplied with two-way adjustment valve, temperature sensor and frost thermostat (*expansion PCB included*).



## EM-Box

The EM-Box distributes extract air between kitchen and bathroom. If the range hood runs via the ventilation system and is operating, extract air flow from the bathroom is reduced to ensure that there is enough air to allow the cooker hood to extract cooking odours. To protect the system, the EM-box is fitted with a metal filter, which efficiently eliminates fat particles from range hood air.



## DBTU damper

If there is not enough space to fit an EM-box, Nilan offers a DBTU damper, which can be fitted between kitchen and bathroom. The damper functions precisely like the EM-box but requires longer cables.



## Cooker hood filter box

If the extract air needs extra filtration, Nilan can supply a Cooker hood filter box. This can provide extra protection of the ventilation unit if you connect a cooker hood that has not got good filters. It can also help air extraction from, for instance, dormitory rooms where cooker hoods are rarely installed.



## Water trap

To prevent "false" air being sucked into the system via the condensate drain, the system must be fitted with a water trap. While there is water in the condensate drain, the water trap works well. However, during the summer months when there is no condensation of extract air, the water trap will dry out (and therefore cease to prevent "false" air intake). A Nilan water trap with ball prevents "false" air flow all year round.



## Vibration absorbers

It is important to ensure that the ventilation unit does not transfer vibrations to the building. The ventilation unit should therefore be placed on a vibration absorbing material. Nilan can supply effective vibration absorbers to place under the ventilation unit. They are sold in packs of 4.



## Flexible silencing

For easy fitting and excellent noise reduction between the system and the distribution box and/or between the system and roof vents.



## Pollenfilter ISO ePM1 50-65% (F7)

Comfort CT500 are as standard with ISO Coarse >90% (G4) filter delivered. If someone in the housing suffers from pollen allergy, it is possible to order a ISO ePM1 50-65% (F7) pollenfilter to minimize the amount of Pollen in the supply-air.



## Heating cable

To protect the condensation outlet against frost, a 3 or 5 metre-long self-regulating heating cable can be ordered.



## Gateway with APP solution

Comfort CT500 can be controlled with a smartphone APP via a gateway connection. Connect the Nilan Gateway to the CTS602 control system. This allows for a cloud connection to the unit. The gateway is available in two different versions - with either a LAN or a WiFi connection to a router.



## Expansion PCB

The expansion PCB provides additional functions for the CTS602 control unit.



## CO<sub>2</sub>-sensor

Installing a CO<sub>2</sub> sensor allows for ventilation speed to be pre-programmed with the CTS602 and to increase ventilation at higher CO<sub>2</sub> levels in the extract air. CO<sub>2</sub> levels are programmable (*expansion PCB required*).



## Extension cable HMI control panel

The control panel for the ventilation unit is connected up with a short wire so it can be installed close to the unit. If you place the unit so the control panel is out of sight, for instance in a cupboard or in the loft, you can order a 15 m extension cable with plug. This allows you to place the control panel where it is visible to the user.

It is important that the control panel is visible so the user can see alarms when, for example, filters need replacing.

# OPERATION

## Frost protection

All ventilation units with a counterflow heat exchanger will ice up if the outdoor temperature is below freezing for a prolonged period.

The extracted air condenses when it is cooled down during heat recovery. The high temperature efficiency will slowly turn the condensate to ice, which will block up the counterflow heat exchanger unless action is taken to remedy this.

Consideration must be given to whether the unit's operation can be protected during a lengthy period of frost or whether it is acceptable to decrease its operation.

In homes which are occupied at night, it would be advisable to protect the unit against frost when the outdoor temperature is coldest by using a pre-heating element. On the other hand, if the ventilation is for an office, it may be acceptable to decrease the operating level at night.

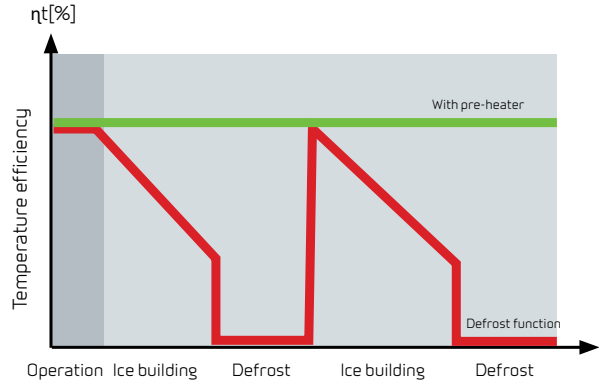

The energy used for the preheating is not wasted, as it ensures a constant high temperature efficiency

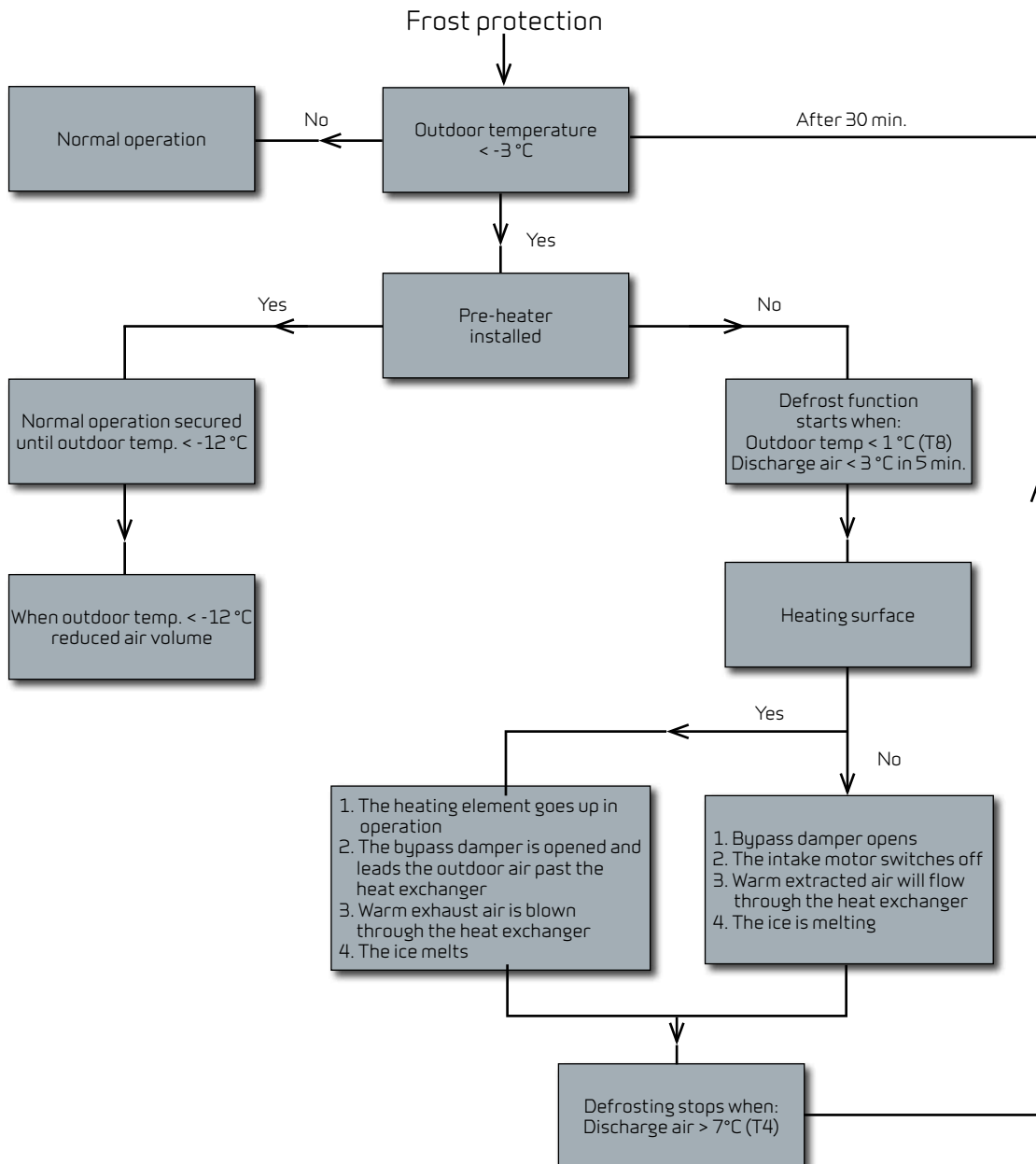

# DELIVERY AND HANDLING

## Transport and storage

Comfort CT500 is shipped in protective packaging for transport and storage.  
Comfort CT500 must be stored in a dry place in its original packaging until installation.  
The packaging should only be removed immediately prior to installation.

## Installation conditions

During installation, future service and maintenance should be taken into account. We recommend a minimum gap in front of the unit of 60 cm.

The unit must be installed level for the sake of the condensate drain. The condensate drain requires clearance of min. 12,5 cm under the drain nozzle.

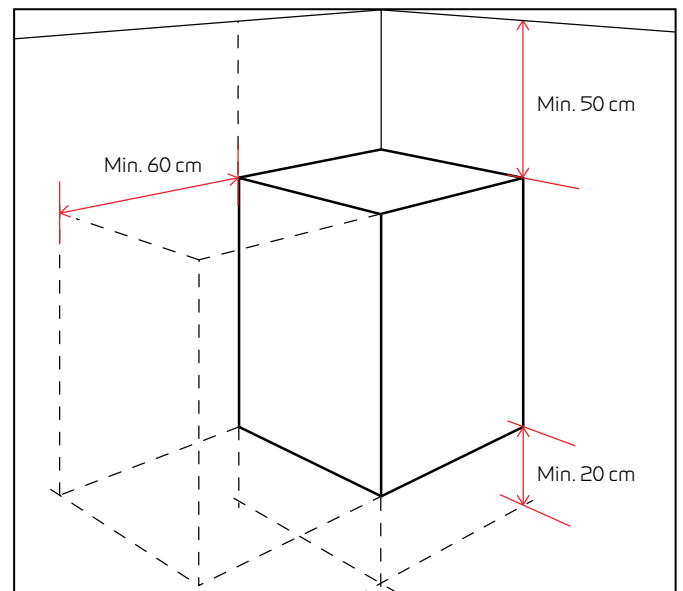

## Installation of electric heating element

Electric heating elements (accessories) are fitted in the duct. The heating element must be insulated using fire-resistant insulation material.

The electric heating element must be connected by an authorised electrician.

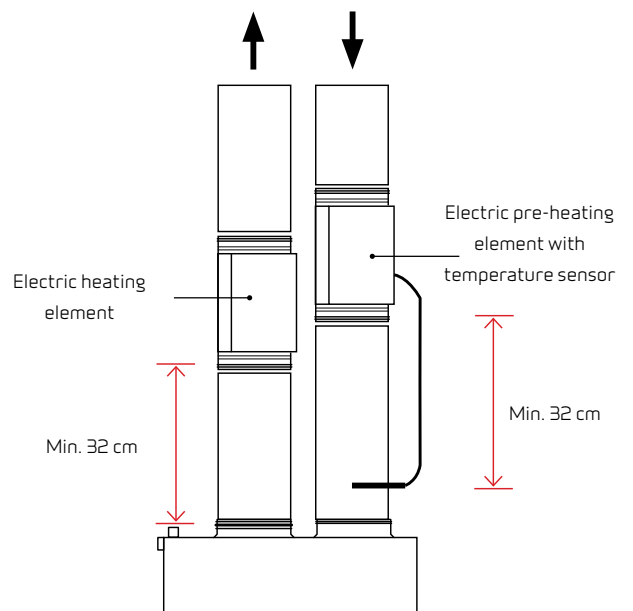

# INFORMATION FROM A TO Z

Nilan develops and manufactures premium-quality, energy-saving ventilation and heat pump solutions that provide a healthy indoor climate and low-level energy consumption with the greatest consideration for the environment. In order to facilitate each step in the construction process - from choosing the solution through to planning, installation and maintenance - we have created a series of information material which is available for download at [www.nilan.dk](http://www.nilan.dk).



**Brochure**  
General information about the solution and its benefits.



**Product data**  
Technical information to ensure correct choice of solution.



**Installation instructions**  
Detailed guide for installation and initial adjustment of the solution.



**User manual**  
Detailed guide for regulation of the solution to ensure optimum day-to-day operation.

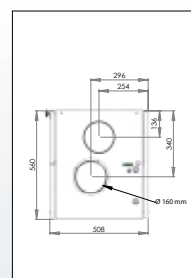

**Drawings**  
Tender documents and 3D drawings are available to download for planning purposes.

[WWW.NILAN.DK](http://WWW.NILAN.DK)

Visit us at [www.nilan.dk](http://www.nilan.dk) to find out more about our company and solutions, download further information and find your nearest dealer.



Nilan A/S  
Nilanvej 2  
8722 Hedensted  
Denmark  
Tel. +45 76 75 25 00  
Fax +45 76 75 25 25  
[nilan@nilan.dk](mailto:nilan@nilan.dk)  
[www.nilan.dk](http://www.nilan.dk)